

# EVO™ 1

## Basic Anchoring

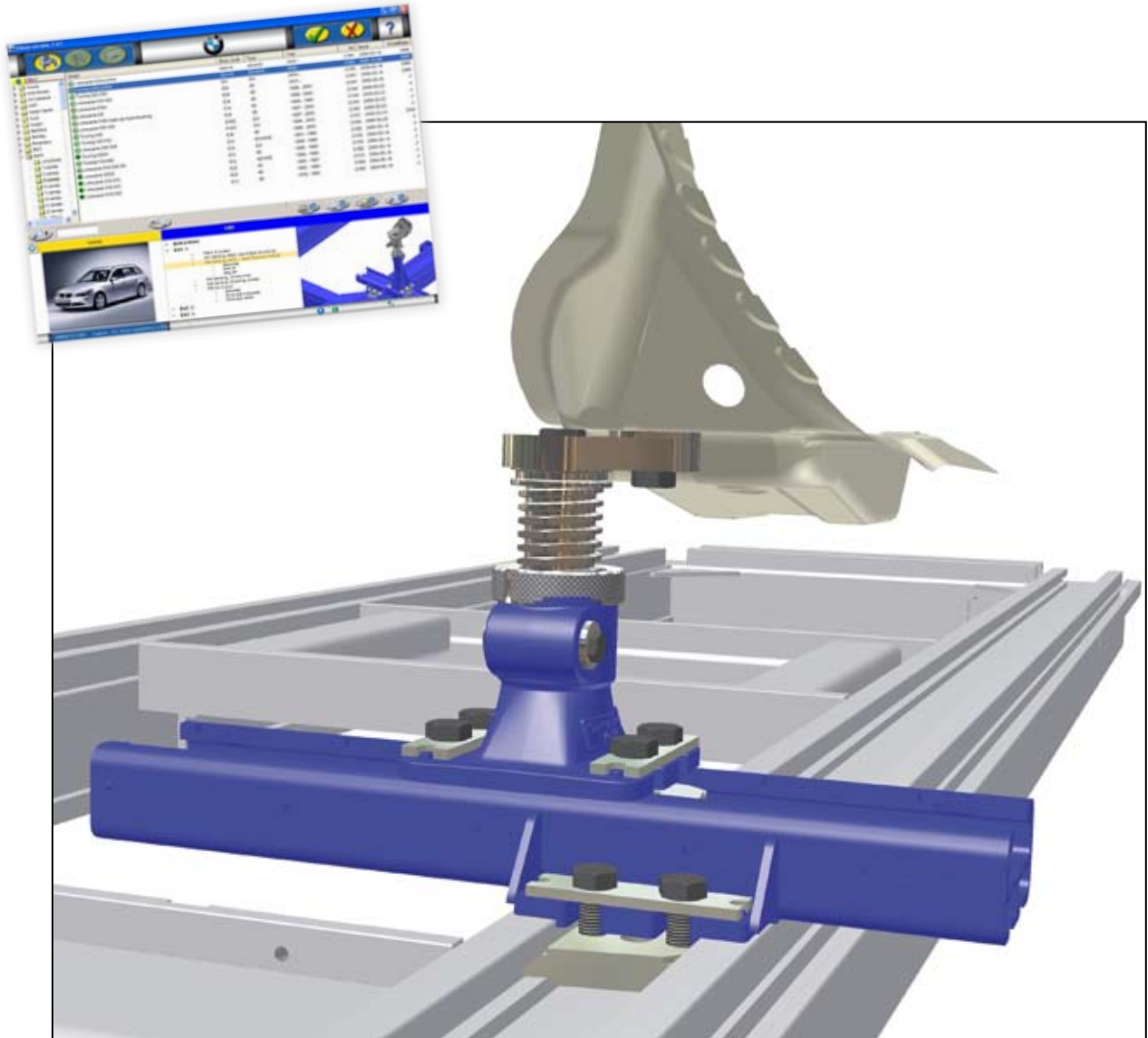

The basic system for anchoring, holding and side support during the repair. Including 3 Towers, Multi Purpose Clamp, Track plates, Bushings with adapter, Chain holder and Torque Bar for heavy operations.

Basic System EVO1		
Description	Pcs	Art. No
E100, Trackplate	1	151 50 01 310
B626, Camlock	6	133 01 10 081
E140, Downpull/chainholder	1	151 50 01 301
E130, Chainholder	1	151 50 01 302
E110, Tower 110	1	151 50 01 101
E170, Tower 170	1	151 50 01 102
E290, Tower 290	1	151 50 01 104
E105, Tool	1	151 50 01 115
E150-15, Adjustable holder (short)	1	151 50 01 107
E150-24, Adjustable holder (Long)	1	151 50 01 108
E120, Lock Wedge, cpl	2	151 50 01 311
Snap ring	3	151 50 01 113
E164, Nut	2	151 50 01 110
E165, Gearplate set	2	151 50 01 307
E166, "Plus" plate	1	151 50 01 118
E145, Clamp bracket	1	151 50 01 305
E115, MPC Clamp	1	151 50 01 304
E190, Adapter for bushing	1	151 50 01 160
E191-10, Bushing 10	1	151 50 01 161
E191-12, Bushing 12	1	151 50 01 162
E191-14, Bushing 14	1	151 50 01 163
E191-16, Bushing 16	1	151 50 01 164
E125, Angle holder 90°	1	151 50 01 124
E175, Torque Bar	1	151 50 01 300
E175-10, Torque Bar bracket	1	151 50 01 203

### The new Universal Holding & Anchoring System for the Future.

The EVO System is modular and upgradable. The EVO System is integrated with Car-O-Liner's Data and Software and supports the complete vehicle repair process with Multimedia, Instructions and Data. Our revolutionary concept – The EVO System will help you to maximize your business performance.

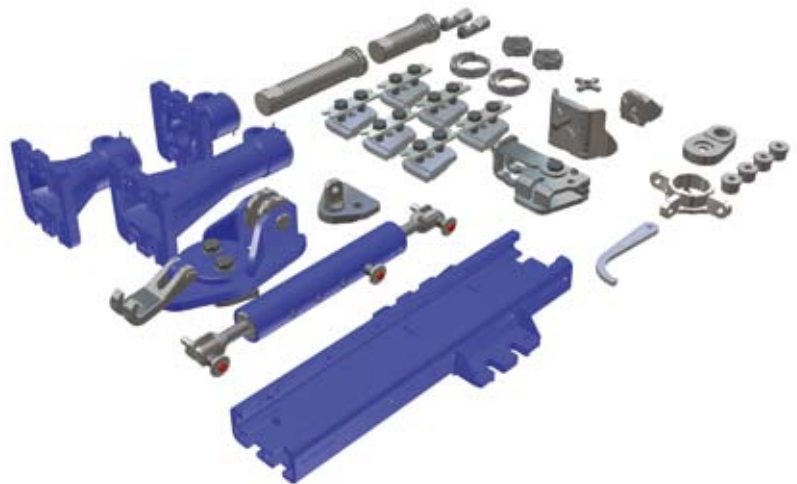

*The purpose of EVO 1 is to give additional support to the standard clamp set-up when making extra hard pulls.. Standard set up is proposed in the Vision System.*