

Performance Track 2500

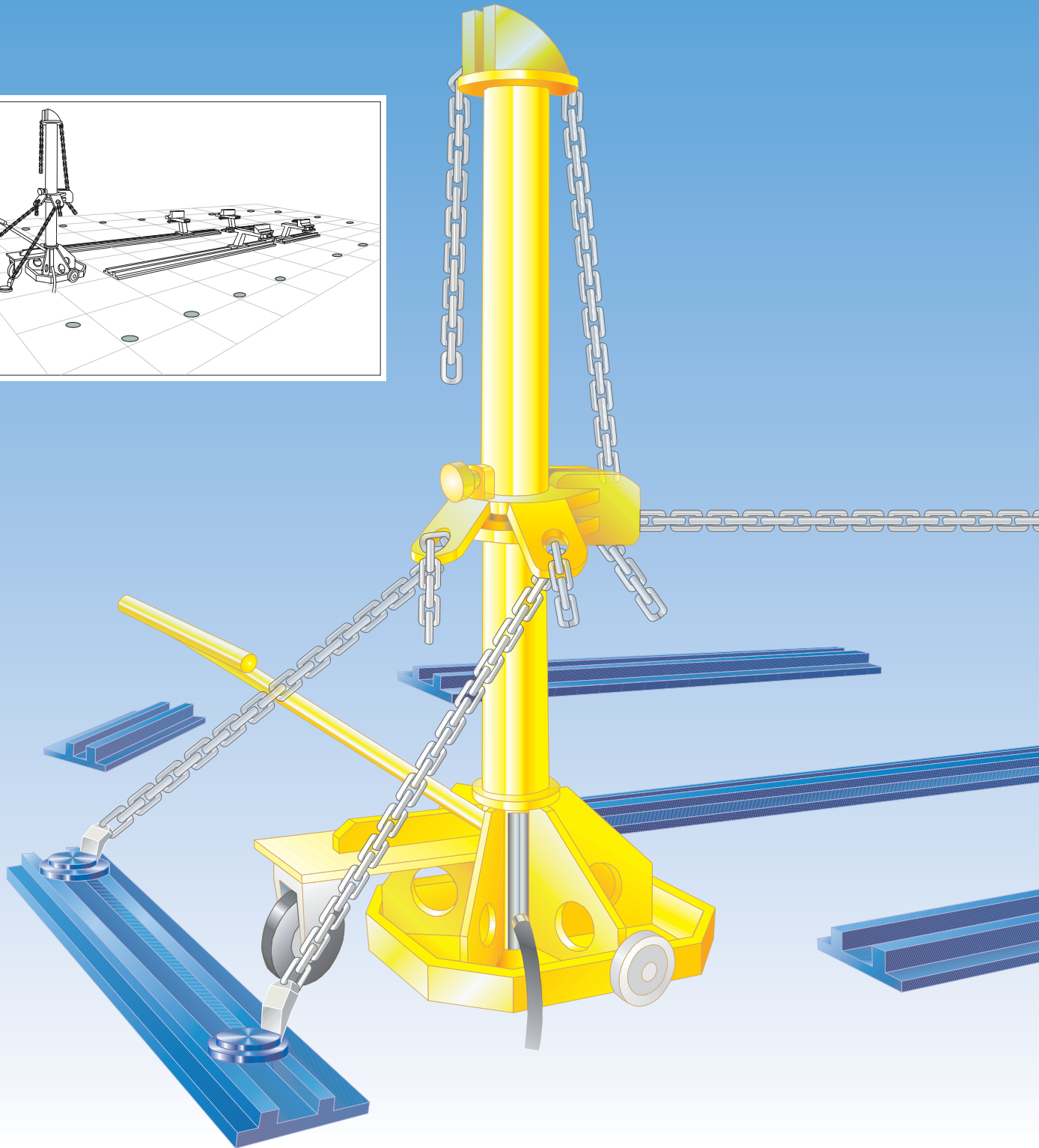
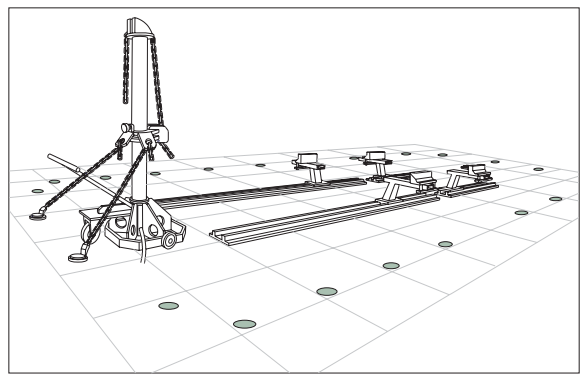

CAR-O-LINER'S floor mounter

Performance Track 2500 is the Car-O-Liner solution for floor based collosion repair systems.

- Performance Track 2500 follows Car-O-Liner's industry proven, easy-to-learn and time-efficient repair procedures.
- Affordable and space efficient. Ideal for multiple shop layouts where stall space cannot be dedicated to a conventional rack or bench system.
- Fast, chainless anchoring and easy set-ups for pulling allow for quick measuring and repairs.
- The powerful pulling tower uses standard 10-ton hydraulics and provides 360° pulling access.
- Reversible bench mountings hold virtually any full-frame car, narrow-frame truck or unibody vehicle.
- Finely milled steel tracks provide a smooth level surface for to-the-millimeter accuracy.
- Car-O-Liner's data sheets, in electronic or printed format provide up-to-date vehicle measurements.
- Performance Track 2500 is compatible with our universal 3D mechanical or computerized measuring systems.
- You can choose the entire layout shown here or any number of tracks and/or anchor pots – simply choose the Performance Track 2500 layout needed in your body-shop.

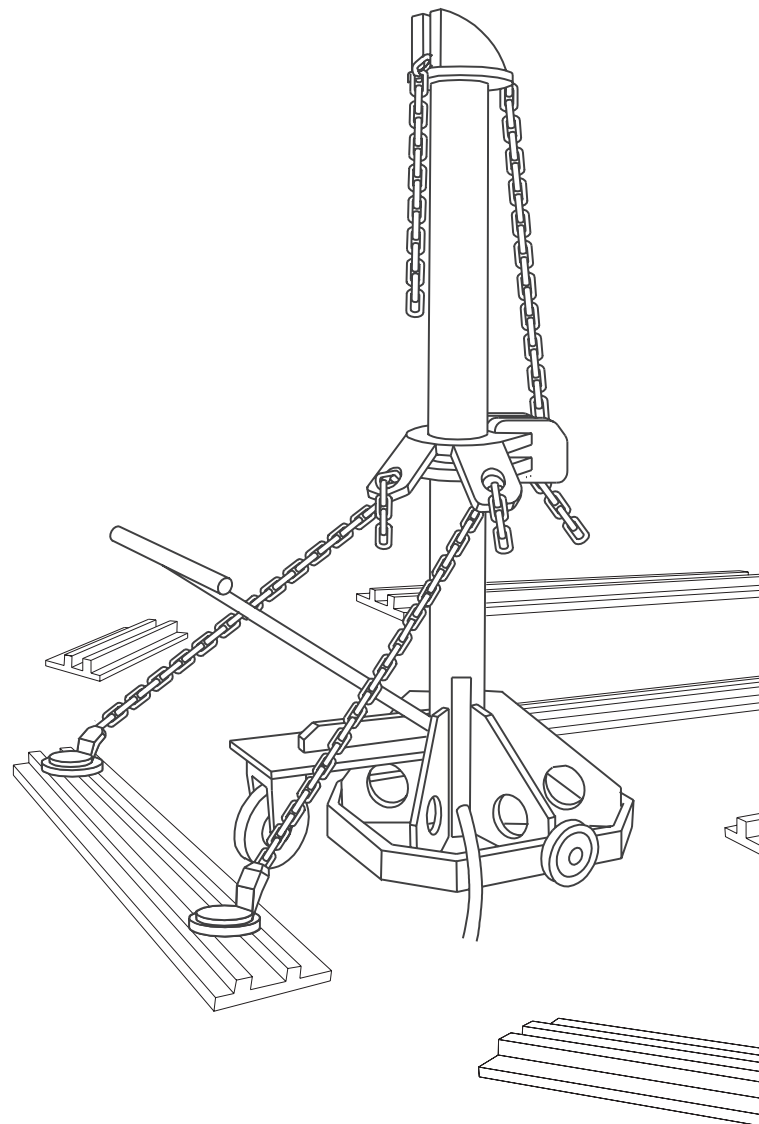

Detail of track section.



Detail of anchor pot.

pulling and anchoring system

This new system has been specifically designed for the modern body-shop where specific equipment is needed for different types of vehicle damage (i.e. light vs. heavy damage)

Car-O-Liner's newly developed 10-ton hydraulic pulling tower freely operates on any configuration of floor tracks, providing full freedom to direct the pulls necessary for correct repair.



A working combination of floor tracks and anchor pots (as shown here) is another advantage when using Performance Track 2500.

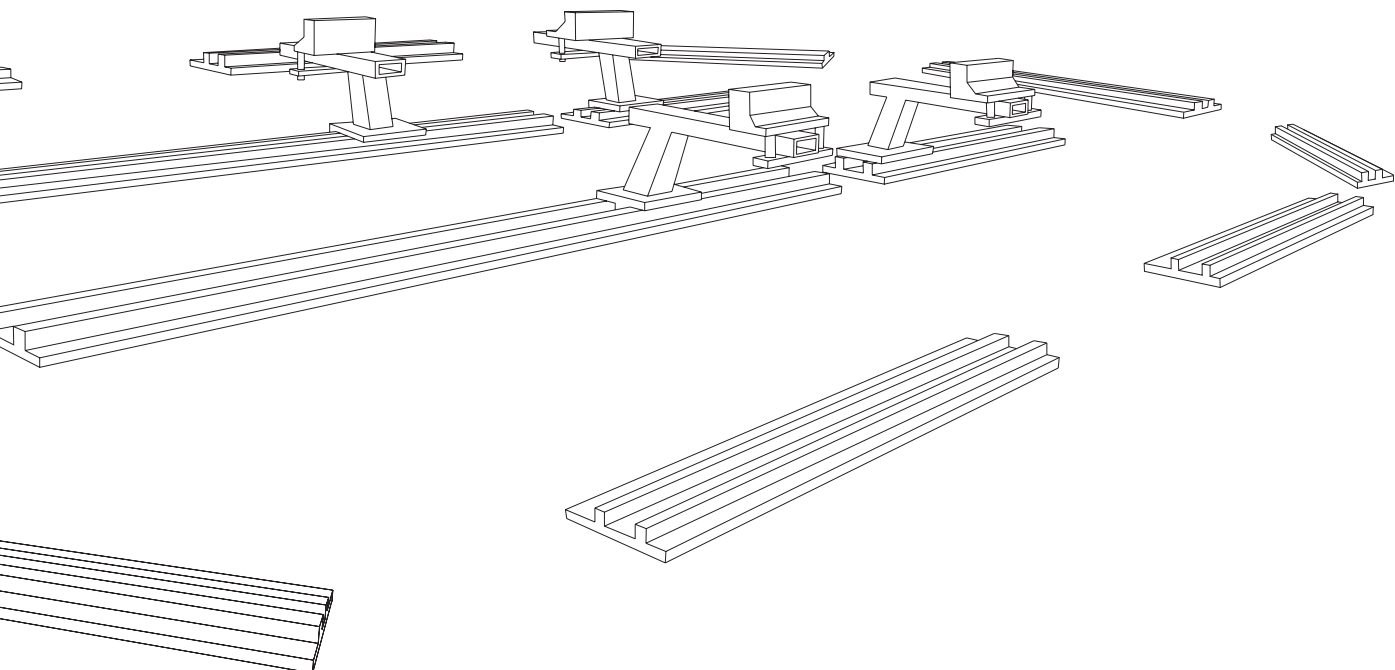
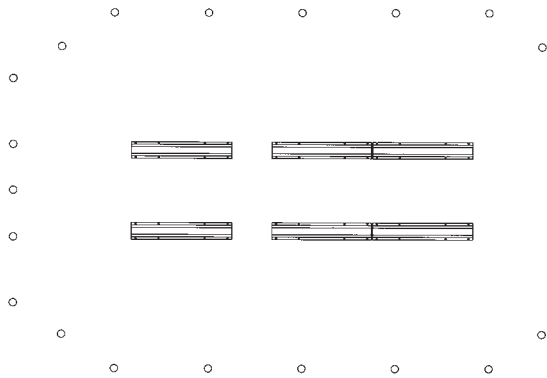
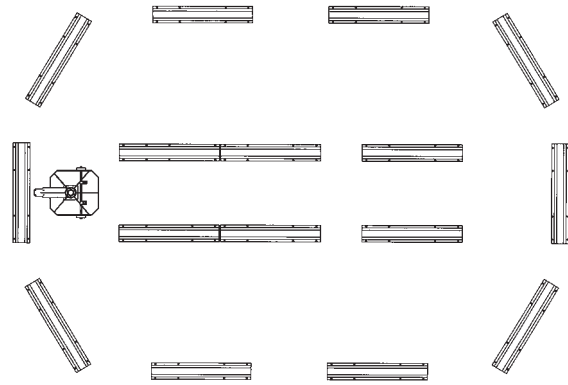

Performance Track 2500 answers the needs of the modern body-shop – with specific equipment for different types of vehicle damage.

Performance Track 2500 features 1,2 meter floor track sections which can be freely installed in the pattern that best suits each body shop. The track sections hold a wide range of vehicle holding, support and repair components from the Car-O-Liner accessories range. Simple chain-locking or structural vehicle clamping can be used for quick repair of light damage. The Performance Track 2500 easily adapts to the specific needs of your body-shop, with space saving and affordable equipment!



Performance Track 2500 uses existing Car-O-Liner holding accessories, specially clamps and truck repair system.



Performance Track 2500 is fully compatible with any of Car-O-Liner's measuring systems and our extensive bank of vehicle data.

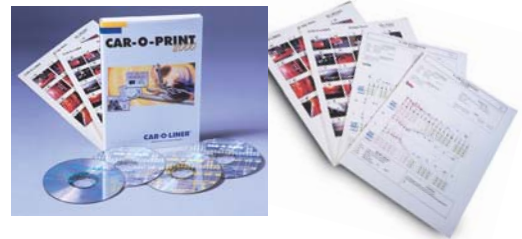

Car-O-Liner data is also available on CD ROM.



For more information on the Performance Track 2500, or any of our collision repair systems, please contact your Car-O-Liner distributor.

CAR-O-LINER®

Box 7, SE-736 21 Kungsör, SWEDEN
Tel. +46 227 412 00 Fax. +46 227 319 00
www.car-o-liner.se info@car-o-liner.se

Performance Track 2500 Components

- Floor Track sections (B86)
- Pulling tower (D19)
- Bench mountings (B39BR)
- Camlocks (B626)
- Universal chassis clamps (B106)
- Chain 2,4 m, with hooks
- Anchor pots
- 10 ton hydraulic cylinder and pump
- Optionals
- Measuring bridge support (M405)*
- Chain holder (B631)**

* Needed if using Car-O-Liner measuring systems.

** To lock holding chains of Pulling tower. Needed if floor segments are used instead of anchor pots.